

Perforator

Plastic Converting

High speed perforation of pe film.

- For production of e.g. tablecloths and drop cloths on roll
- In-line or out-of-line



} Precise perforation at high-speed }

Table covers



Drop cloths



IP 900, IP 1100 and IP 1700

The perforator is perfect for production of special film at high speed, where only perforating is needed. You can produce e.g. tablecloths, drop cloths and cover foil on roll. It is a stand-alone module and can be placed in-line with an extruder, together with a bag making machine, or only a winder. The perforator has a rotating, servo-driven perforating system. The rotating knife causes low tension on the film and ensures constant operation of the perforator.

The knife is turnable and has four cutting edges, which gives the possibility to make different cuttings. Fine adjustment of the knife is made from outside during production. The perforator is prepared for mounting of print mark registration.

The distance between two perforations is adjusted from a separate control panel or controlled by a print mark.

Technical data for Perforator

	IP 900	IP 1100	IP 1700
Max. film speed	250 m/min (820 ft/min)*	180 m/min (600 ft/min)*	130 m/min (430 ft/min)*
Max. cycles/min	600	600	600
Max. film width	900 mm (35.4 in)	1100 mm (43.3 in)	1700 mm (70 in)
Min. perforating distance	300 mm (11.8 in)	300 mm (11.8 in)	400 mm (15.7 in)

*) Depending on film quality and thickness.
Can be supplied with print registration.

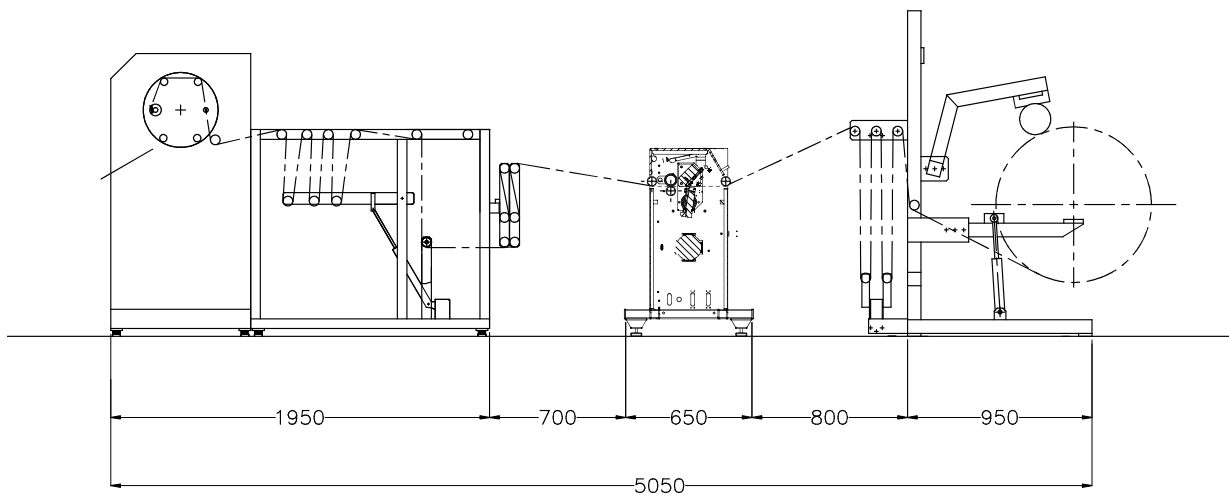

Perforator

We always focus on your production demands – therefore all Roll-o-Matic developments are customer-driven and customer-oriented. The PERFORATOR lines have been developed according to our

customers' requirements for user-friendly, easy to operate, high capacity equipment where the key parameters are: a modest investment, stability, outstanding performance and return on investment.

Watch video of
IP 900

